

**Gardner**  
**Denver**

INDUSTRIAL

# Vacuum Products

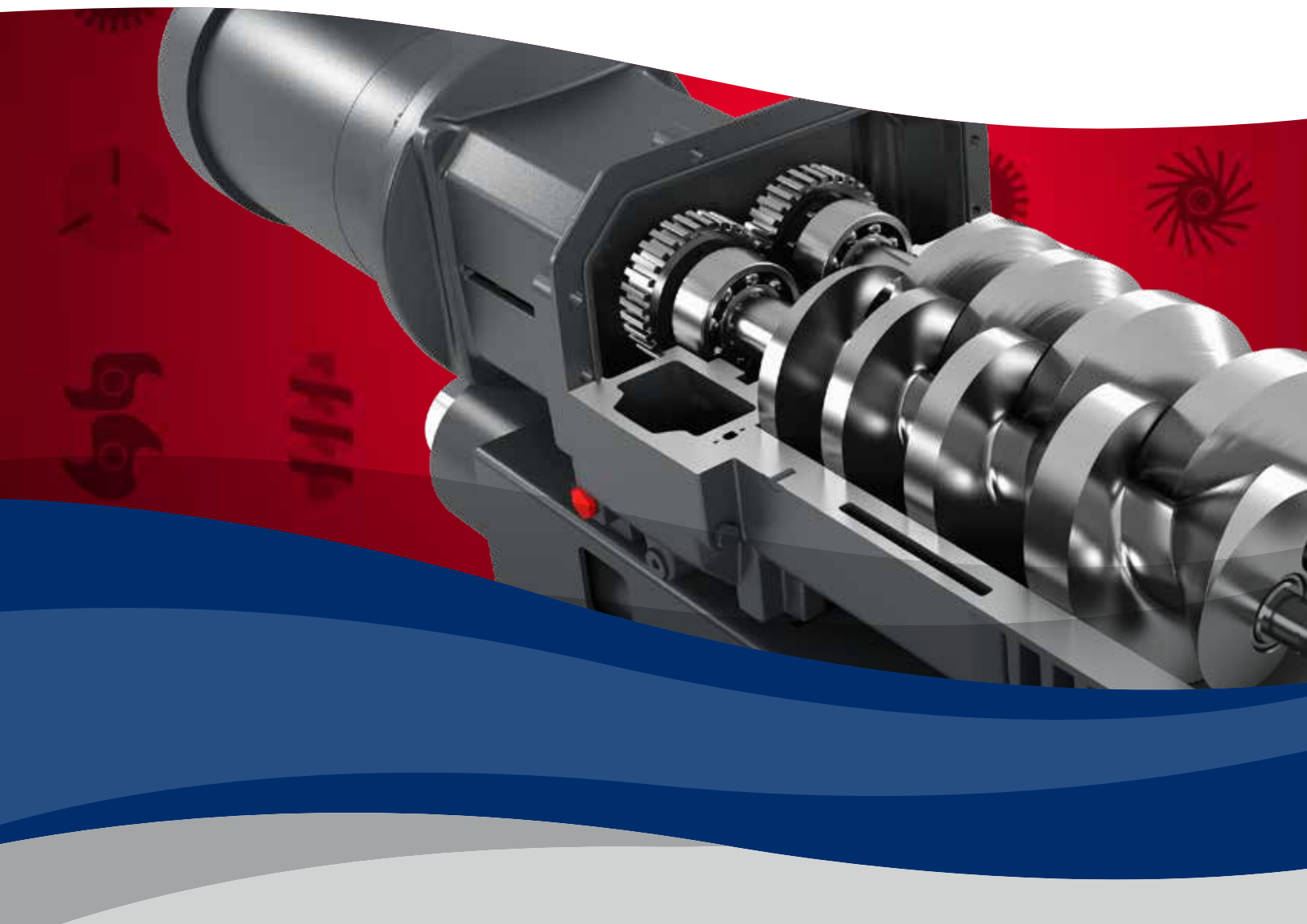

Did you know about...

# our NETWORK?





- Our distribution network is factory-trained and certified
- Local service includes support for re-build

We're Where You Need Us

Did you know about...

# our EXPERTISE?

We were the  
**FIRST**  
**TO PATENT**  
regenerative  
blower technology



Used on the  
international  
space station

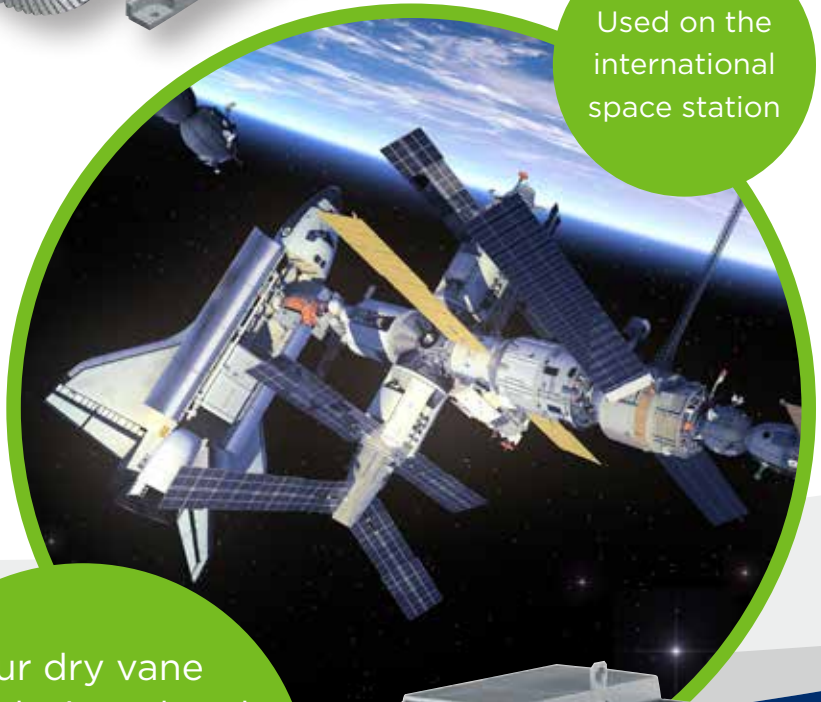

Our dry vane  
was designed and  
produced for

# NASA



Our  
**PATENTED**  
Liquid Ring System  
**RECLAIMS**  
its own water

We  
**INVENTED**  
**THE FIRST**  
combination  
vac/pressure duty  
vane pump



Our lubricated  
vane uses unique  
& proprietary  
alloys



We Have a Legacy of  
**Inventing** Original Solutions

Did you know about...

# our RANGE?

6

TECHNOLOGY  
STYLES

PRECISION  
OPTIONS FOR  
**YOUR**  
APPLICATION

OVER  
**420**  
MODELS



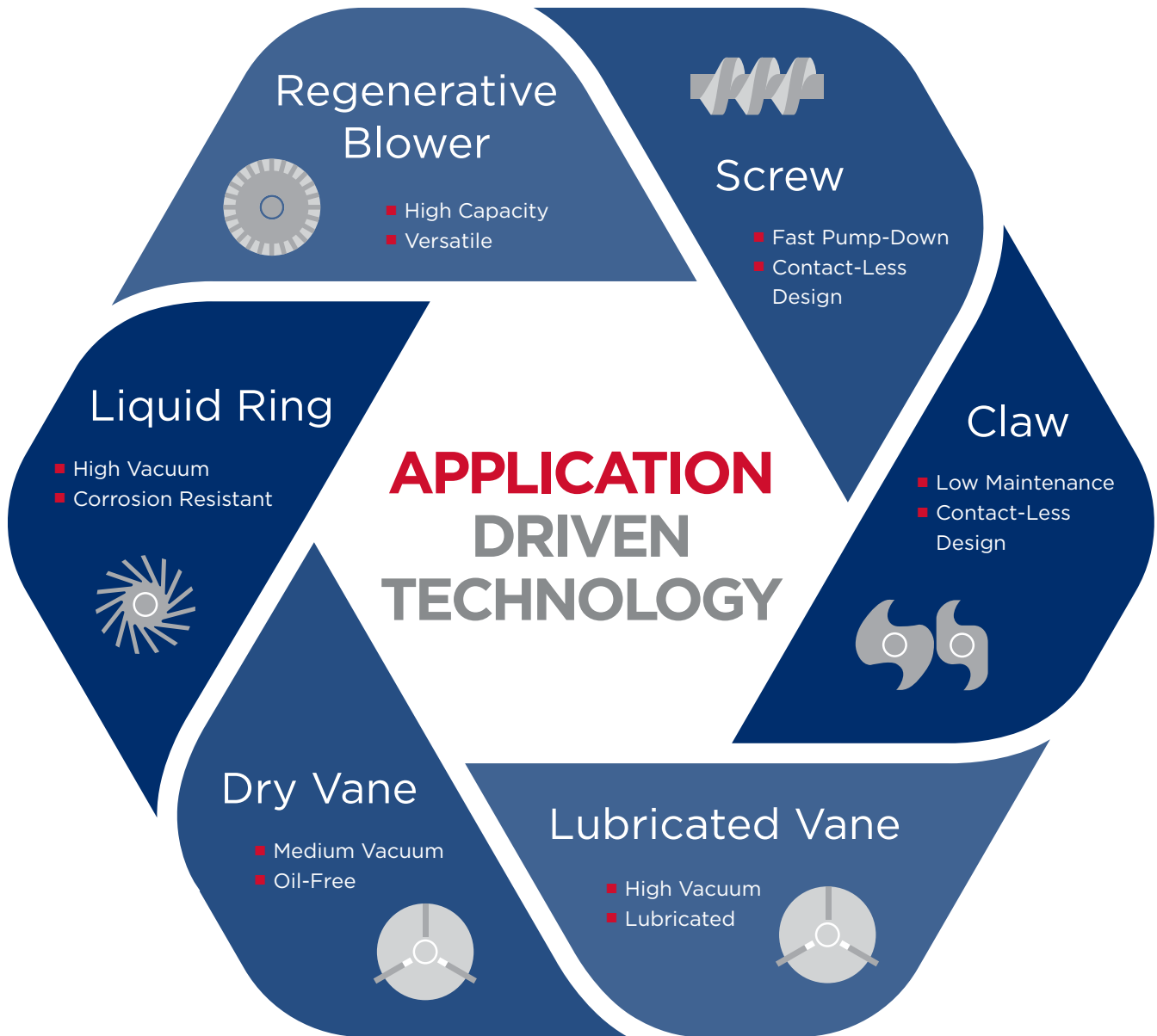

Gardner Denver provides more technology styles than anyone else.  
 This means **YOU** can tailor technologies to **YOUR** needs.

We're your first and **ONLY** call!

Did you know we operate in almost...

**EVERY INDUSTRY?**

Plastics

Aerospace      CNC Routers  
Soil Remediation      Automotive  
Dental      Medical      Oil Separation  
Printing      Environmental

WoodWorking      Laboratory

Packaging

Conveying

Wind Turbine Blades

Parts Drying







Food Processing

Manufacturing

Surface Suction

Agriculture

Extrusion

# Water Treatment

Biotech

Degassing

Poultry

Fish Farming

Particle Analysis

Beverage

Paper Production

Production

Did you know about our...

# REGENERATIVE BLOWERS?



## Advantages at a Glance

- High CFM capacities moderate pressure/vacuum
- Ideal for point of use applications
- Easy installation
- Contact-less Operation
- Tolerant to dust ingestion
- VFD Compatible
- Quiet operation
- Up to 40,000 operating hours without maintenance



Technology	Specifications		
Regenerative Blowers	UP TO		
G Series	1,550	CFM	
	14	PSI	
	16	inHg	

## Operating Principle

1. Gas is taken in through the inlet and enters the side channel
2. The rotating impeller imparts velocity energy into the gas in the direction of rotation. Centrifugal force in the impeller blades accelerates the gas outward, increasing pressure. Kinetic energy is imparted with every rotation resulting in further pressure increase.
3. The side channel narrows at the rotor, sweeping gas off the impeller blades and discharging it through the outlet silencer where it exits the blower.

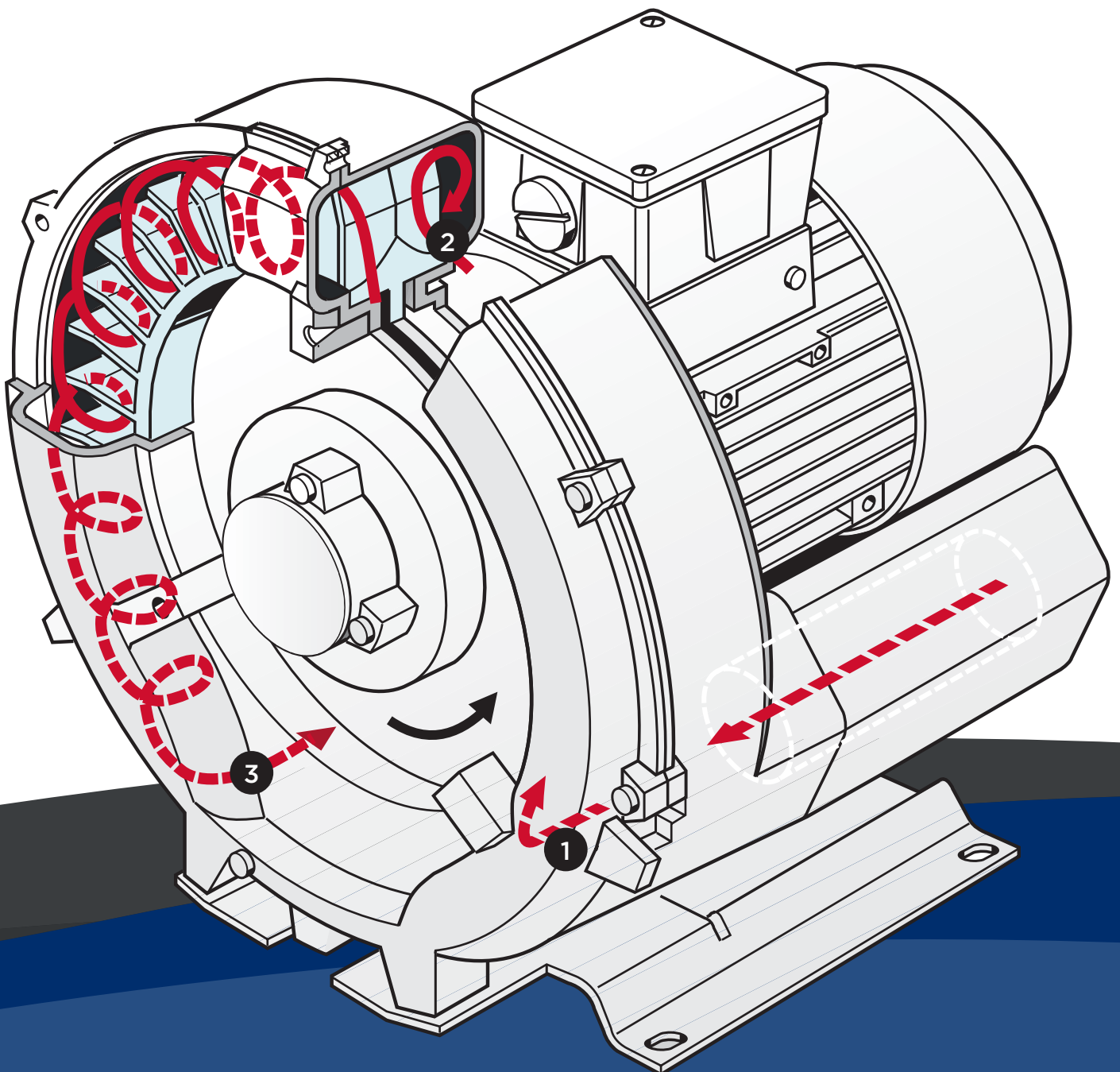

Did you know about our...

# LUBRICATED VANE?



Technology	Specifications	
Rotary Vane Pumps  V Series	<b>UP TO</b> <b>903</b> CFM <b>29.91</b> inHg <b>0.38</b> Torr	

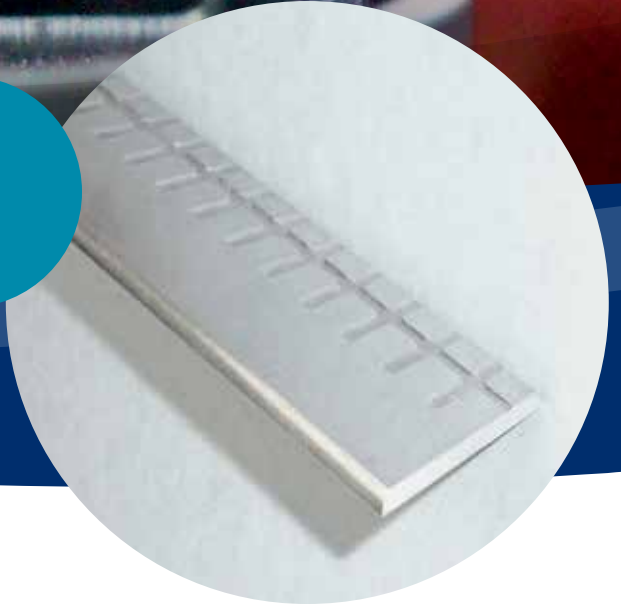

### Why Elmo Rietschle?

- Deep vacuum level
- Faster pumping speeds
- Quieter, smaller footprint
- Patented filter design
- Easier maintenance, less downtime

### Why Aluminum Alloy?

- Proprietary material blend
- Won't delaminate or absorb oil: eliminates stuck/failed vanes
- Channels can be milled to enhance lubrication
- Incredibly durable
- Soft enough to wear if lubrication deteriorates
- Track record: years of operation
- 5 Year Warranty!



Did you know about our...

# DRY VANE?



Technology	Specifications		
Rotary Vane Pumps V Series	UP TO <b>91</b> <b>22</b> <b>25.5</b> 112	CFM PSI inHg Torr	



### Dry Vane Advantages

- Multiple sizes
- Oil-free
- Optimized cylinder design
- Long-life graphite vanes
- Environmentally friendly
- Minimal maintenance
- Low noise level
- Compact size

### Ideal For

- Vacuum Lifting
- Medical Vacuum
- Pick n' Place
- Woodworking, CNC Routers
- Central Vacuum System



Did you know about our...

# CLAW?



## Claw Advantages

- Contact-less design: oil-less compression
- Service intervals up to 5 years
- Environmentally friendly
- Compact footprint
- Lowest in class dBA

Technology	Specifications		
Claw C Series	UP TO		
	<b>671</b>	CFM	<div style="width: 60%; height: 15px; background-color: #76b82a;"></div>
	<b>32</b>	PSI	<div style="width: 100%; height: 15px; background-color: #c00000;"></div>
	<b>27</b>	inHg	<div style="width: 85%; height: 15px; background-color: #00838f;"></div>





Did you know about our...

# SCREW?

See why we have **Best-In-Class**  
**PERFORMANCE**

- Contact-less design
- Fast pump down-times
- Innovative screw pitch design
- Oil-free compression
- Low cost of ownership
- Most efficient technology

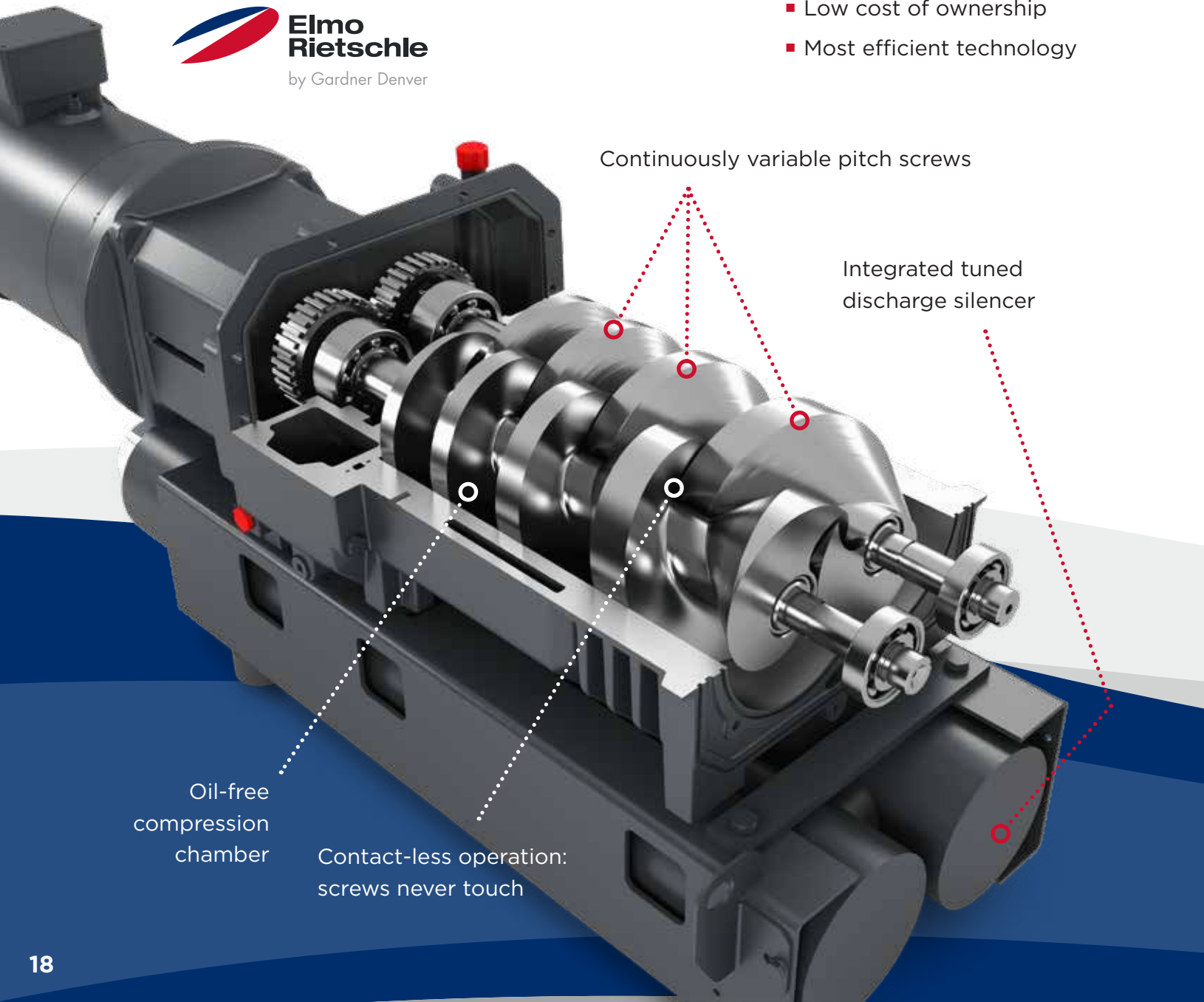

Technology	Specifications
Screw Pumps  S Series	<p><b>UP TO</b></p> <p><b>212</b> CFM</p> <p><b>29.917</b> inHg</p> <p><b>0.075</b> Torr</p>

### Screw vs. Alternative Technology AT THE SAME HORSEPOWER

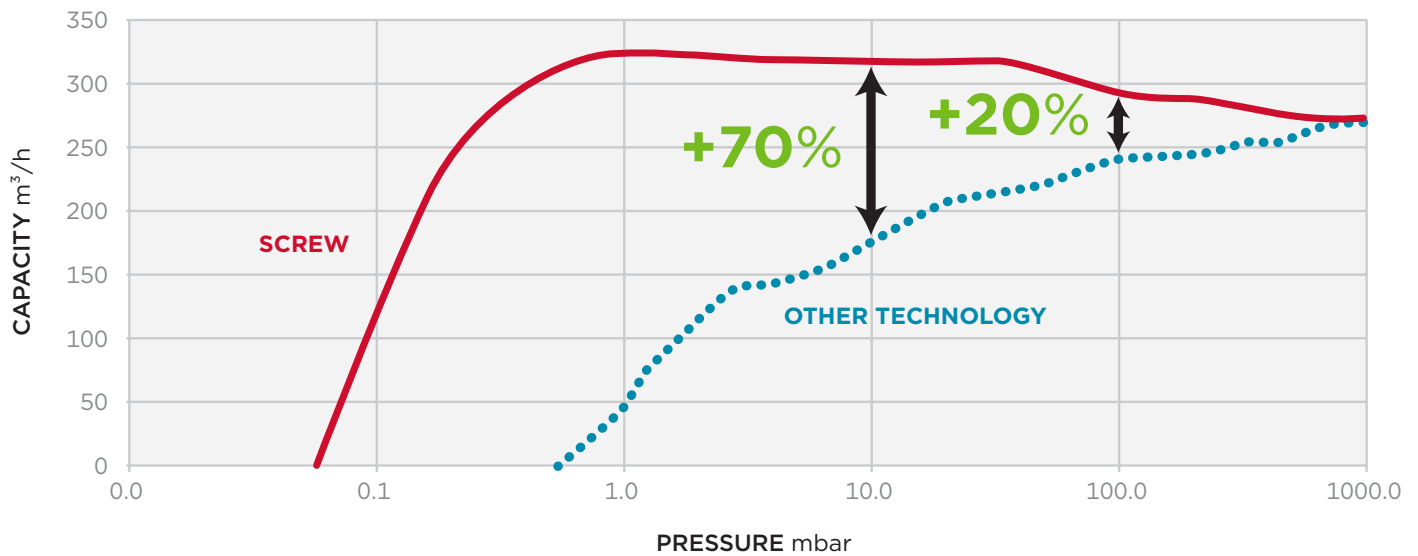

Up to **70%** more flow during pump-down

= **FASTER** pump-down

= **FASTER** cycle time

= **MORE \$**

FOOD PLANT  
PRODUCTION MANAGER

“After installing the VSI

**OUR PRODUCTION**

MORE THAN

**DOUBLED**

from 4 Packs to  
9 packs per minute.”

Available in  
Chemical Grade  
& Industrial  
Versions

Did you know about our...

# LIQUID RING?

High Water Carry-Over

= **LOWEST** in Class for Horsepower Use

= **SAVINGS**



## Small but Mighty



- Patented water reclamation system
- Unique coatings
- Stainless Steel options
- Bronze alloy impellers
- Anti-cavitation as standard

Technology	Specifications		
Liquid Ring Pumps L Series	UP TO		
	<b>353</b>	CFM	
	<b>36</b>	PSI	
	<b>29</b>	inHg	

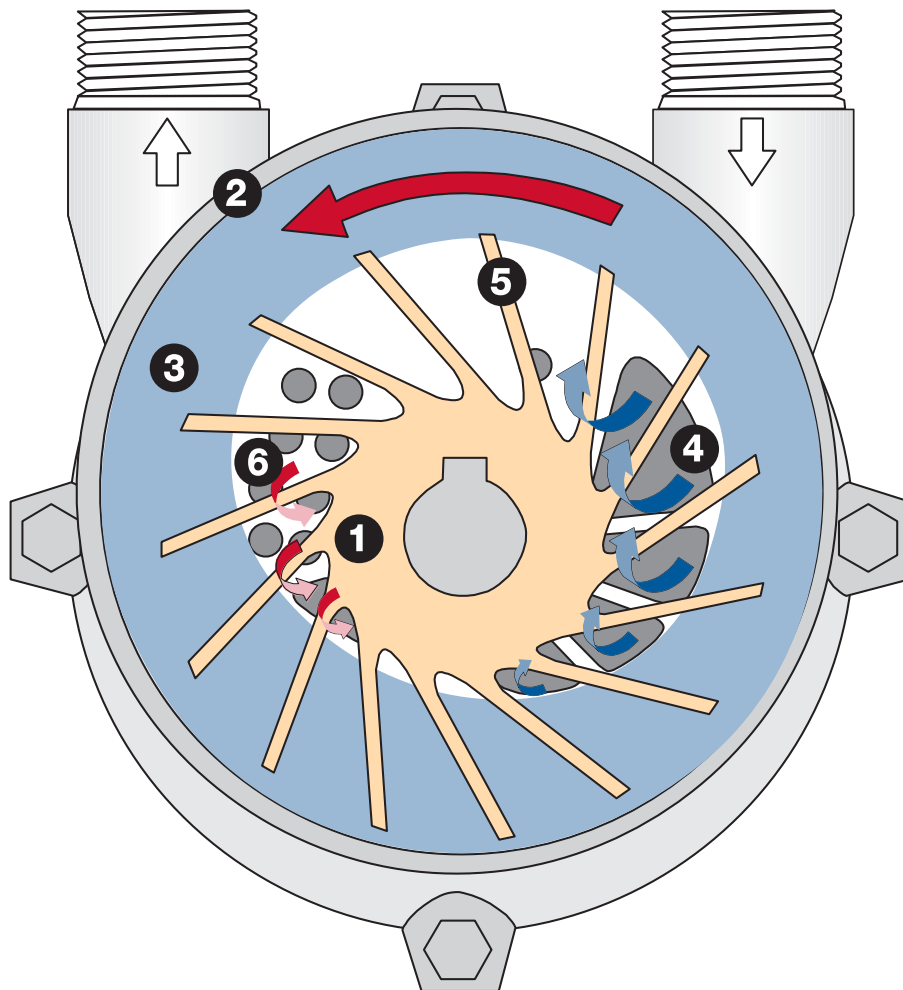

## Operating Principle

- The impeller **(1)** is the only moving part.
- It rotates without contact inside the pump casing **(2)**.
- A rotating liquid ring **(3)** seals the impeller on the front and seals its blades against one another.
- Gas flows through the inlet slot **(4)** into the blade cells.
- The impeller is offset within the casing. This creates variable compression chambers between the blades **(5)**, which compresses the gas within a full revolution.
- In order to stabilize the ring, liquid is also permanently sucked into the compression chamber and is expelled **(6)** together with the conveyed gas.

Did you know about our...

# ENGINEERED SYSTEMS?

- We can offer system design and specification support
- In-house engineering team
- Compliant with chemical and medical grade specifications
- Meets NFPA 99 & CSA Code
- Expandable systems for future facilities growth
- System multiplexing to meet demand requirements
- Modular systems with increased handling flexibility
- Compressed air and vacuum systems are available





One Company, One Source, **One Choice**  
Technical Expertise for You

The leader in every market we serve  
by continuously improving all business processes  
with a focus on innovation and velocity

**Gardner  
Denver®**

**Gardner Denver, Inc.**

1800 Gardner Expressway  
Quincy, IL 62305  
866-249-2275

[www.gd-elmorietschle.com](http://www.gd-elmorietschle.com)



©2018 Gardner Denver, Inc. Printed in U.S.A.  
VAC-IND-PROD 2nd Ed. 5/18

 Please recycle after use.